

As electronics seamlessly weave their way into our lives, sensors play an increasingly important role. Light sensors are very simple and inexpensive, allowing their inclusion in multitudes of consumer products from night lights to cell phones. There are a multitude of ways to sense light. The simplest optical sensor is a photo resistor. Photodiodes are the next step in complexity. When photons bombard the junction, current is produced. A photo transistor exhibits the same general characteristics as the photodiode, with the addition of current amplification. It requires more bias current and therefore has a bit more noise, but enjoys a larger lux range. (1k to 100k instead of 7k to 50k). These traditional methods suffer from poor dark current response and temperature sensitivity.

Intersil Light Sensors

Shrinking device sizes have allowed the creation of a hybrid device like the ISL29102. It places a calibrated photodiode, a non-linear current amplifier and a micropower op amp on a single monolithic IC, as shown in Figure 1. The integrated non-linear current amplifier boosts and converts the photodiode signal in a square root fashion, extending the light input dynamic range while maintaining excellent sensitivity at dim conditions. The photodiode array has a peak sensitivity at 550nm similar to human eye response. The input luminance range is 0.3 lux to 10k lux.

Using the same calibrated photodiodes, the ISL29020 includes a micropower 16-bit Analog-to-Digital Converter (ADC) and a serial I²C interface. The block diagram is shown in Figure 2. The output from the photodiode is calibrated and fed through a current amplifier before entering an integrating ADC, which rejects 50/60Hz noise, and the I²C interface delivers the digital output signal. In normal operation condition, the power consumption is less than 65µA. The input luminance range is 0.04 lux to 64k lux.

Intersil Proximity Sensors

The ISL29015, shown in Figure 3, contains two photodiode arrays which convert light into current. One photodiode array responds to ambient light and the other responds only to infrared light. When joined with an infrared LED, this second LED array can operate as a proximity sensor. After light is converted to current during the light signal process, the current output is converted to digital by a built-in 16-bit ADC. An I²C command reads the ambient light or IR intensity in counts. The converter is a charge-balancing integrating type 16-bit ADC. The chosen method for conversion is best for converting small current signals in the presence of an AC periodic noise. A 100ms integration time, for instance, highly rejects 50Hz and 60Hz power line noise simultaneously.

The ADC has I²C programmable range select to dynamically accommodate various lighting conditions. For very dim conditions, the ADC can be configured at its lowest range, Range 1. For very bright conditions, the ADC can be configured at its highest range, Range 4.

Ambient Light Sensing Application

Ambient light sensors are included in many laptops and cell phones to sense the environment lighting conditions, allowing for adjustment of the screen's backlight to comfortable levels for the viewer. The range of "comfortable levels" is dependent on the room's light. The relationship is shown in Figure 4. Understandably, a screen's brightness needs to increase as the ambient light increases. What is less obvious is the need to decrease the brightness in lower light conditions-for comfortable viewing and to save battery life.

In a cell phone, the ambient light sensor are located under a protective cover glass. Because of this protection, most of the ambient light is obstructed. The obstruction reduces the amount of light to be measured, requiring a solution with low-light accuracy. For the accuracy needed in low-light conditions, the best sensor choice is the integrated photodiode with an ADC. Note that the inclusion of a high-pass filter can minimize power supply noise from coupling into the backlight illumination.

Figure 5 shows the complete automatic back light control circuit for cell phones. The ISL29102 senses ambient light intensity and outputs a proportional voltage. The light sensor output current injects into the feedback input of the White LED driver. In a bright environment, the light sensor sources more current into the feedback node. As a result, it reduces the White LED output current and reduces the White LED output light intensity. The extension of battery life is remarkable.

Proximity Sensing Application

While ambient light sensors use the visible part of the spectrum, proximity sensors use the infrared (IR) wavelengths. Instead of measuring the surrounding light, a proximity sensor gauges the closeness of an object - like your face by detecting the IR reflection strength.

Proximity sensors operate with reflections, as shown in Figure 6. An IR LED is chosen to send out an infrared signal. Any object in front of the IR LED causes some of that signal to be reflected back to proximity sensor. More signal is reflected when an object is closer. After calibrating (for losses like the filtering of the cell phone glass), the output of the proximity sensor reveals the distance of an object.

There are many design considerations when using a proximity sensor. The first is obviously the choice of the IR

LED to be used. The second is the composition of the object to be sensed. Most sensors are calibrated with one of the standard reflective surfaces, like 18% reflective gray paper. More signal will be returned to the sensor if the surface has a higher reflectivity.

A second set of design considerations are concerned with mechanical issues. For example, how well is the IR LED isolated from the sensor? Any leakage will taint the readings. Both the placement of the components and any obstructions (purposeful or incidental) need to be considered. Additionally, there is usually a panel of glass to protect the electronics and the user from each other. That cover glass has its own filtering spectrum that must be included in the design.

Conclusion

A wide variety of optical sensors are available in small packages at reasonable prices. Passive solutions have been serving consumers for decades in night lights and still digital cameras. Active solutions have increased the range and usefulness of ambient light sensors. Typical active solutions integrate a photo transistor or a photodiode with a current amplifier. When greater resolution, low-light capability, power supply rejection, or a disabling function would be useful, the Intersil ISL29xxx family extends the usefulness of typical ambient light sensors.

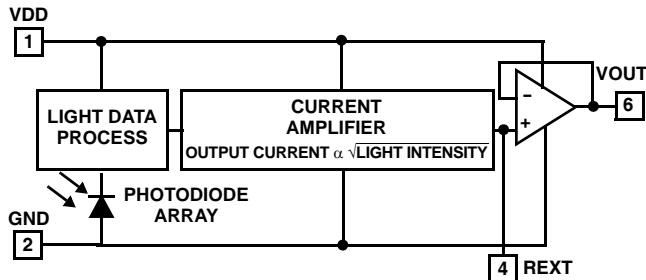

FIGURE 1. BLOCK DIAGRAM OF ISL29102 AMBIENT LIGHT SENSOR WITH INTEGRATED AMPLIFIER

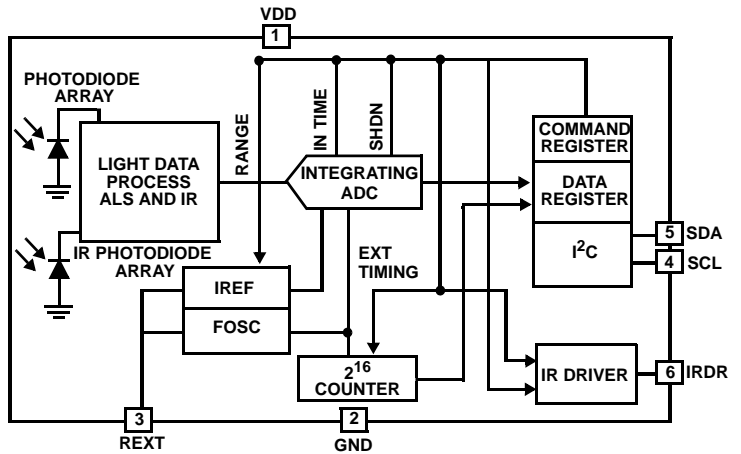

FIGURE 3. BLOCK DIAGRAM OF ISL29015, AMBIENT LIGHT SENSOR AND PROXIMITY SENSOR

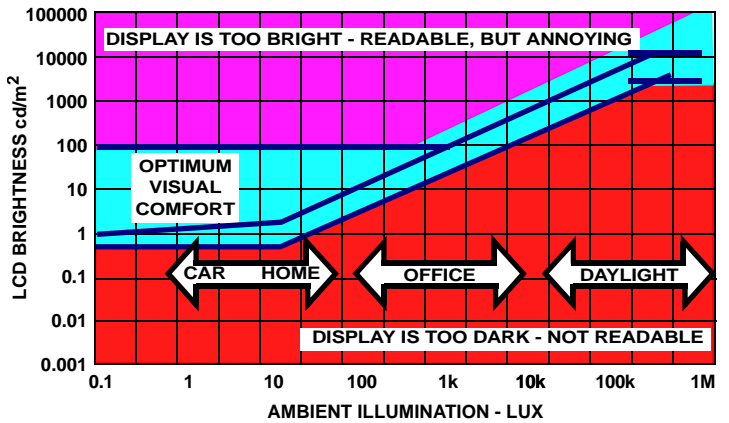

FIGURE 4. GRAPH OF DESIRED BRIGHTNESS WITH RESPECT TO AMBIENT ILLUMINATION

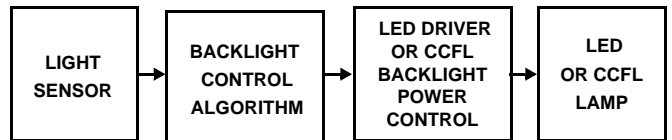

FIGURE 5. BLOCK DIAGRAM OF LIGHT SENSING SYSTEM IN A LAPTOP OR CELL PHONE

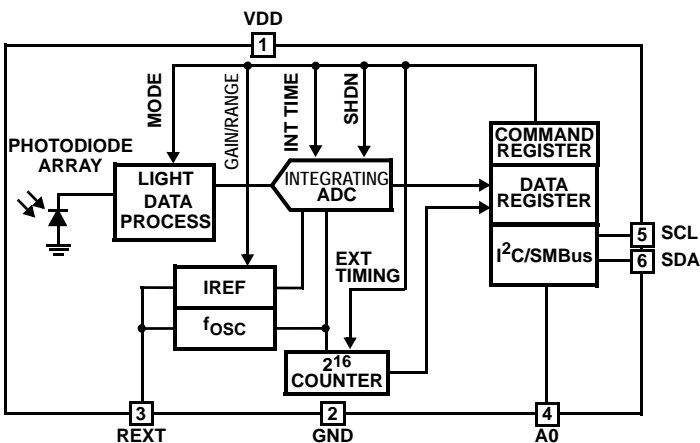

FIGURE 2. BLOCK DIAGRAM OF ISL29020, AMBIENT LIGHT SENSOR WITH ADC, AND I²C INTERFACE

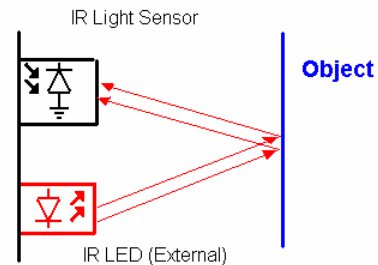

FIGURE 6. APPLICATION DIAGRAM OF PROXIMITY SENSOR

Intersil Corporation reserves the right to make changes in circuit design, software and/or specifications at any time without notice. Accordingly, the reader is cautioned to verify that the Application Note or Technical Brief is current before proceeding.